

Product Specification

Ord.-No.: **111 819**

Specification: Multi-Max reinforcement clamp 50x50 mm
St/tZn, Ø 4-16mm / Ø 10 or fl. 30x3.5mm

Performance: Connecting clamp according to EN 62561-1 for the connection of round- or flat conductors with the reinforcement in the concrete foundation.

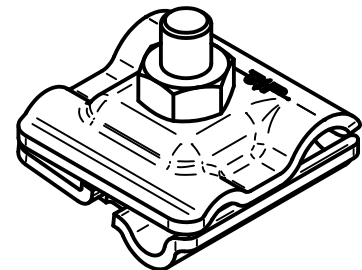
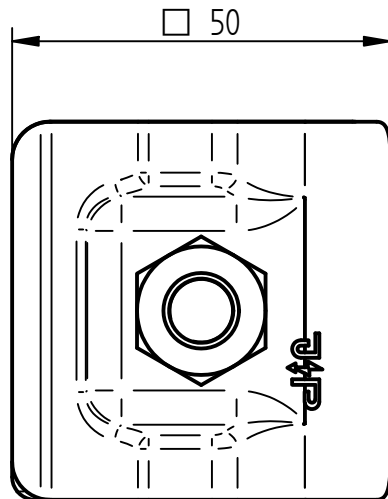
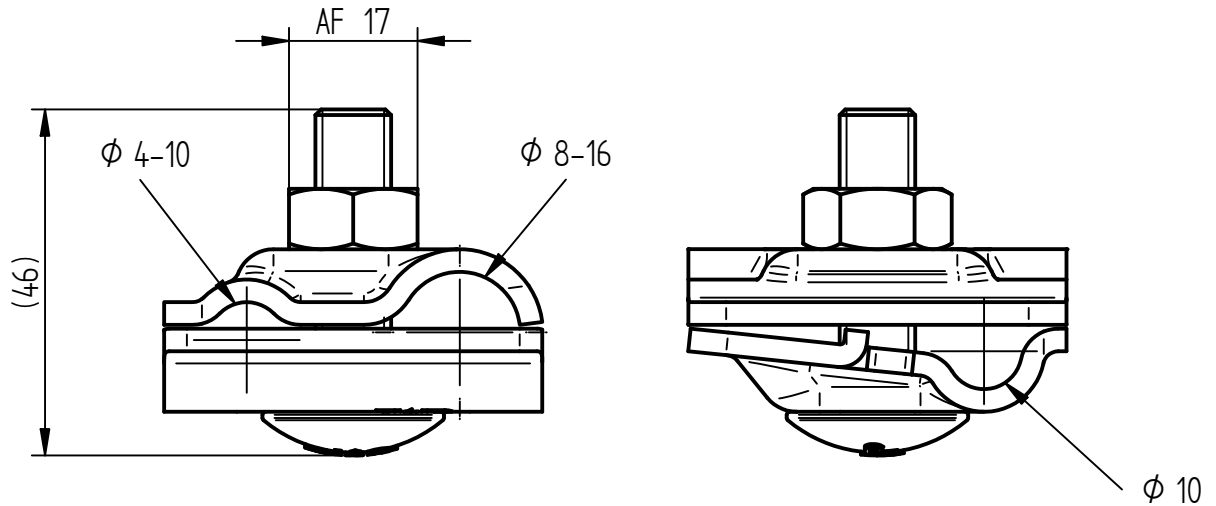

Material of clamp	St/tZn
Screw	Carriage bolt M10 with hexagon nut, St/tZn
Type of clamp	2-part, round/round-flat
Fit	Ø 4-16 mm / Ø 10 or fl. 30x3.5 mm
Weight	176 g
Standard reference	DIN EN 62561-1
Packing unit	50 units